

The rate constants were determined from the slopes of the lines and their temperature dependency is shown in Fig. 6. The energies of activation were calculated from the Arrhenius relationship to be 65.6 kcal. mole<sup>-1</sup> for the decomposition of potassium nitrate and 34.3 kcal. mole<sup>-1</sup> for the reaction between potassium nitrite and oxygen. The corresponding frequency factors are 10<sup>10.5</sup> sec.<sup>-1</sup> and 10<sup>9.58</sup> sec.<sup>-1</sup>, respectively.

These values are further confirmation of the suggested mechanism involving an initial reaction between nitrite and molecular oxygen, since an activation energy which is approximately equal to the dissociation energy of oxygen would be required if the primary step of the oxidation process involved the dissociation of molecular oxygen.

The corresponding activation energies for the decomposition of sodium nitrate and for the reaction between sodium nitrite and oxygen<sup>6</sup> are 44.7 and 20.7 kcal. mole<sup>-1</sup>. The difference in the en-

ergies of activation for the decompositions of sodium and potassium nitrate is apparently larger than could be accounted for by the difference in dissociation energies of the N-O bond. This however may be attributed to the more extensive polarizing power of the sodium ion. The sodium ion, which induces a relatively greater positive and negative charge in the oxygen molecule at the surface of the melt could cause oxygen to be more strongly attracted to the nitrite ion and accordingly the steepness of the potential energy profile would be effected. Therefore the height of the barrier is a function of both, the N-O bond strength and the repulsion between the nitrites and oxygen.

**Acknowledgment.**—The author expresses his gratitude to J. Campisi for carrying out the X-ray analyses and to S. Gordon for reviewing the manuscript.

NEWARK 2, NEW JERSEY

[CONTRIBUTED FROM RESEARCH DEPARTMENT, STANDARD OIL COMPANY (INDIANA)]

## Organic Ions in the Gas Phase. II. The Tropylium Ion

BY PAUL N. RYLANDER, SEYMOUR MEYERSON AND HENRY M. GRUBB

RECEIVED SEPTEMBER 12, 1956

Dissociation of alkylbenzenes by electron impact is generally interpreted as proceeding through benzyl ions. The mass spectra of labeled ethylbenzenes and toluenes suggest that dissociation of these compounds involves a rearrangement to produce, not the benzyl ion, but the isomeric tropylium ion. This hypothesis can explain in a self-consistent manner a variety of hitherto anomalous observations.

### Introduction

The decomposition of alkylbenzenes and derivatives by electron impact has been generally interpreted as proceeding through benzyl or substituted benzyl ions.<sup>1-7</sup> The ion of mass 91, C<sub>7</sub>H<sub>7</sub><sup>+</sup>, is often the most abundant ion in the mass spectra of these compounds. Formation of this ion by cleavage of a β-carbon-hydrogen or β-carbon-carbon

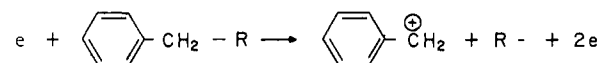

bond has seemed so straightforward that its identity has not been questioned.

However, a number of difficulties encountered in this Laboratory and elsewhere have demanded a careful examination of the C<sub>7</sub>H<sub>7</sub><sup>+</sup> ion. Peculiarities in the spectra of labeled molecules and in correlations of spectra with structures, and inconsistencies in appearance potentials indicate that the origin and nature of this ion may be not quite so simple as has been assumed.

### Origin of the C<sub>7</sub>H<sub>7</sub><sup>+</sup> Ion

Metastable peaks<sup>8</sup> in the spectra of ethylbenzene

$$78.1(106^+) \longrightarrow (91^+) + 15$$

- (1) M. J. O'Neal and T. P. Wier, *Anal. Chem.*, **23**, 830 (1951).
- (2) I. W. Kinney and G. L. Cook, *ibid.*, **24**, 1391 (1952).
- (3) H. R. Lumpkin and B. H. Johnson, *ibid.*, **26**, 1719 (1954).
- (4) D. O. Schissler and D. P. Stevenson, *J. Chem. Phys.*, **22**, 151 (1954).
- (5) F. H. Field and J. L. Franklin, *ibid.*, **22**, 1895 (1954).
- (6) S. Meyerson, *Appl. Spectroscopy*, **9**, 120 (1955).
- (7) F. W. McLafferty, *Anal. Chem.*, **28**, 306 (1956).
- (8) P. N. Rylander and S. Meyerson, *THIS JOURNAL*, **78**, 5799 (1956). See footnote for brief discussion of the significance of metastable peaks and for literature reference.

and toluene

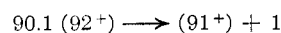

are consistent with simple cleavage of the β-bond. The spectra of deuterated ethylbenzenes, given in Table I, show unequivocally that no hydrogen migration or exchange accompanies this cleavage. The C<sub>7</sub>H<sub>7</sub><sup>+</sup> ion from ethylbenzene-β-d contains no deuterium; those from the α-, *ortho*-, *meta*- and *para*-deuterated isomers retain the deuterium; and those from ethylbenzene-α-d<sub>2</sub> and α,β-d<sub>5</sub> retain two deuterium atoms

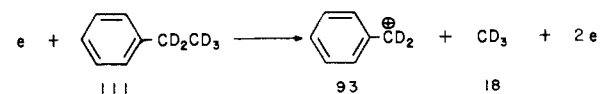
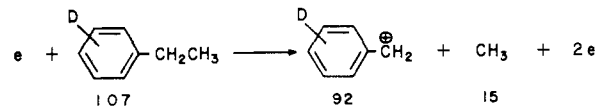
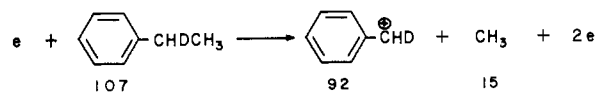
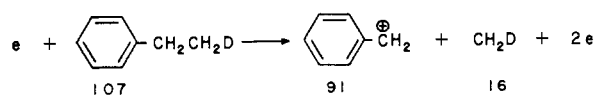

On the other hand, the spectra of deuterated toluenes, shown in Table II, cannot be accounted for by this simple mechanism. The peaks at mass 91 in the spectra of *ortho*-, *meta*- and *para*-deutero-

TABLE I  
 PARTIAL SPECTRA OF LABELED ETHYLBENZENES (COR. FOR NATURALLY OCCURRING C<sup>13</sup>)

Mass	<i>d</i> <sub>0</sub>	<i>α-d</i> <sup>a</sup>	<i>β-d</i>	<i>o-d</i>	<i>m-d</i>	<i>p-d</i>	<i>α-d</i> <sub>2</sub> <sup>b</sup>	<i>α,β-d</i> <sub>3</sub> <sup>c</sup>
111	....	....	....	....	....	....	....	29.7
110	....	....	....	....	....	....	....	4.15
109	....	....	....	....	....	....	1.3	1.98
108	....	....	....	....	....	....	30.7	0.38
107	....	30.4	30.4	30.0	30.4	29.7	1.8	.80
106	30.1	4.51	5.77	5.03	5.02	4.97	0.7	.80
105	5.87	1.37	0.95	1.13	1.25	1.12	2.8	.42
96	....	....	....	....	....	....	....	.27
95	....	....	....	....	....	....	....	.98
94	....	....	....	....	....	....	4.0	1.67
93	....	....	....	....	....	....	100.0	100.0
92	....	100.0	....	100.0	100.0	100.0	0.0	3.66
91	100.0	2.84	100.0	1.61	0.57	0.84	.0	1.21
90	0.79	1.46	0.84	1.43	1.36	1.43	.8	0.92
69	....	....	....	....	....	....	....	.34
68	....	....	....	....	....	....	.2	.35
67	....	0.13	0.09	0.32	0.31	0.18	4.4	4.23
66	0.23	5.77	0.56	5.82	5.96	5.88	4.4	4.07
65	8.50	3.53	7.36	2.86	2.87	2.86	1.9	2.31

<sup>a</sup> May contain 1-2% ethylbenzene-*β-d*. <sup>b</sup> Spectrum uncorrected for 4% ethylbenzene-*d*<sub>3</sub>. <sup>c</sup> Spectrum uncorrected for 5.1% ethylbenzene-*d*<sub>4</sub>, 0.1% *d*<sub>3</sub> and about 3% isomeric-*d*<sub>5</sub>.

toluenes show that 10% of the hydrogen atoms lost in forming C<sub>7</sub>H<sub>7</sub><sup>+</sup> ions are deuterium, which can come only from the ring. The spectrum of toluene-*α-d*, contrary to what one might expect, shows only slightly greater loss of deuterium relative to that of protium than do the spectra of the ring-deuterated

Further, the spectra of the *ortho*-, *meta*- and *para*-deuterated toluenes are indistinguishable. There is none of the orientation effect under electron impact that is shown in more familiar chemical reactions. This peculiarity has been commented upon in the literature,<sup>10</sup> but no explanation has been offered to account for it.

Thus, the hydrogen atoms in the toluene molecule tend to lose identity in the process leading to formation of the C<sub>7</sub>H<sub>7</sub><sup>+</sup> ion.

#### Dissociation Products from the C<sub>7</sub>H<sub>7</sub><sup>+</sup> Ion

The spectra of both toluene and ethylbenzene contain the metastable peak

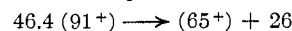

which shows that the C<sub>7</sub>H<sub>7</sub><sup>+</sup> ion dissociates by the path

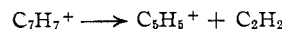

If the C<sub>7</sub>H<sub>7</sub><sup>+</sup> ion has the benzyl structure, it can lose C<sub>2</sub>H<sub>2</sub> in four, or perhaps five, ways

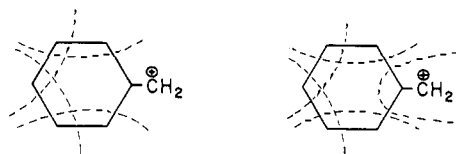

In the first case, if no rearrangement has occurred, C<sub>5</sub>H<sub>5</sub><sup>+</sup> ions derived from C<sub>6</sub>H<sub>5</sub>CHD<sup>+</sup> should all be deuterated and have a mass of 66 units; those from *o*-C<sub>6</sub>H<sub>4</sub>DCH<sub>2</sub><sup>+</sup> should be 75% deuterated; and those from *m*-C<sub>6</sub>H<sub>4</sub>DCH<sub>2</sub><sup>+</sup> and *p*-C<sub>6</sub>H<sub>4</sub>DCH<sub>2</sub><sup>+</sup> should be 50% deuterated. In the second case, the C<sub>5</sub>H<sub>5</sub><sup>+</sup> ions derived from *α*-, *ortho*-, *meta*- and *para*-deuterotoluenes should be, in order, 80, 80, 60, and 60% deuterated. The observed relative intensities for the ions of mass 66—8.7, 9.7, 9.7 and 9.7—are nearly identical.

 TABLE II  
 PARTIAL SPECTRA OF LABELED TOLUENES (COR. FOR NATURALLY OCCURRING C<sup>13</sup>)

Mass	<i>d</i> <sub>0</sub> <sup>a</sup>	<i>α-d</i> <sup>b</sup>	<i>o-d</i> <sup>b</sup>	<i>m-d</i> <sup>b</sup>	<i>p-d</i> <sup>b</sup>	<i>α-d</i> <sub>3</sub> <sup>c</sup>	<i>α-d</i> <sub>3</sub> <sup>d</sup>
95	....	....	....	....	....	100.0	100.0
94	....	....	....	....	....	96.3	92
93	....	77.4	75.7	75.6	75.5	50.8	46
92	67.7	100.0	100.0	100.0	100.0	3.49	
91	100.0	13.3	10.8	10.6	11.1	2.86	
69	....	....	....	....	....	0.52	
68	....	....	....	....	....	3.41	
67	....	0.86	0.87	0.88	0.87	8.80	
66	1.03	8.72	9.70	9.66	9.65	6.20	
65	12.4	6.20	5.35	5.47	5.20	4.59	

<sup>a</sup> Value of 100.0 assigned to relative intensity at mass 91, C<sub>7</sub>H<sub>7</sub><sup>+</sup> ions. <sup>b</sup> Value of 100.0 assigned to relative intensity at mass 92, C<sub>7</sub>H<sub>6</sub>D<sup>+</sup> ions. <sup>c</sup> Spectrum uncorrected for 4.0% toluene-*d*<sub>3</sub>, 0.4% *d*<sub>1</sub> and 0.4% *d*<sub>0</sub>. <sup>d</sup> Relative intensities of 94 and 93 corrected for 4% toluene-*d*<sub>2</sub> on the assumption that the *d*<sub>2</sub>-compound contributes about equally at mass 94 and 93.

isomers. The peak at mass 94 in the spectrum of toluene-*α-d*<sub>3</sub> shows that 66% of the hydrogens lost in this process are protium, which, in this case, can come only from the ring. The spectrum of toluene-*α-d*<sub>3</sub> of 95% isotopic purity confirms the observation<sup>9</sup> from the spectrum of lower-purity material that the nominal processes

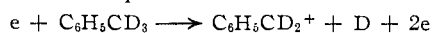

and

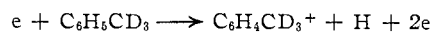

occur nearly in the ratio 3:5, as if all the hydrogens were equivalent in the dissociation of this compound.

(9) J. B. Farmer, I. H. S. Henderson, C. A. McDowell and F. P. Lossing, *J. Chem. Phys.*, **22**, 1948 (1954).

(10) F. L. Mohler, V. H. Dibeler, L. Williamson and H. Dean, *J. Research Natl. Bur. Standards*, **48**, 188 (1952).

Not only are these values nearly identical, but they are close to the value to be expected if all seven hydrogens in the  $C_7H_7^+$  ion were equivalent. The value predicted on this basis is five-sevenths the relative intensity of  $C_6H_5^+$  ions, mass 65, in the spectrum of unlabeled toluene (12.4), or 8.87. Similarly, in the spectrum of toluene- $\alpha$ - $d_3$ , the relative intensity of  $C_6H_2D_3^+$  ions of mass 68 is 3.41; it agrees well with the value that would follow from complete equivalence of the protium and deuterium atoms in the  $C_7H_4D_3^+$  ion, 3.49, or 3.34 if the spectrum is corrected for the toluene- $d_2$  impurity.

The corresponding data from the ethylbenzene spectra lead to the same picture. Again the observed relative intensities for the ions of mass 66—5.77, 5.82, 5.96 and 5.88—are nearly identical for all isomers. Again they agree well with the value that would follow from complete equivalence of the seven hydrogens in the  $C_7H_6D^+$  ion, 6.07. In the spectra of ethylbenzene- $\alpha$ - $d_2$  and - $\alpha,\beta$ - $d_5$ , the relative intensities of  $C_6H_3D_2^+$  ions of mass 67—4.4 and 4.23—agree well with the 4.05 that would follow from complete equivalence of the protium and deuterium atoms in the  $C_7H_5D_2^+$  ion.

### Tropylium Ion

The finding that the seven hydrogens in the  $C_7H_7^+$  ion are indistinguishable implies a symmetrical structure. We propose that this ion is not the familiar benzyl ion, but tropylium instead

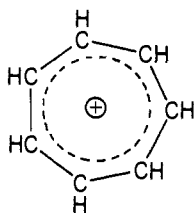

*A priori*, rearrangement to a seven-membered ring might occur before, during, or after cleavage of the  $\beta$ -bond. The loss of identity of the hydrogens in the formation of  $C_7H_7^+$  from toluene implies that, in this case at least, rearrangement occurs before or during bond-cleavage.

The tropylium ion, which has six conjugated  $\pi$  electrons, was long ago predicted to be a stable cation.<sup>11</sup> Recent isolation of the high-melting salt tropylium bromide confirmed this prediction.<sup>12</sup> Resonance energy of the benzene ring is about 41 kcal.<sup>13</sup> No value has been assigned to the additional energy due to resonance of the type

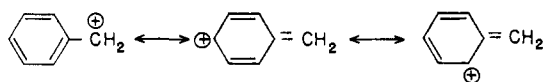

but this should not be much greater than the resonance energy for the benzyl radical, which has been estimated to lie between 11 and 24 kcal.<sup>14,15</sup> One

(11) E. Hückel, *Z. Physik*, **70**, 204 (1931).

(12) W. v. E. Doering and L. H. Knox, *THIS JOURNAL*, **76**, 3203 (1954).

(13) G. W. Wheland, "The Theory of Resonance," John Wiley & Sons, Inc., New York, N. Y., 1944, p. 69.

(14) W. Hückel, *Z. Physik*, **83**, 632 (1933).

(15) M. Szwarc, *J. Chem. Phys.*, **16**, 128 (1948).

estimate of the resonance interaction between the vacant orbital in the benzyl ion and the  $\pi$  electrons places this value as low as zero.<sup>5</sup> Molecular-orbital calculations assign 60 kcal. of resonance energy to the tropylium ion.<sup>16</sup> On the basis of these estimates, tropylium ion should be more stable than benzyl ion by -5 to 19 kcal.

Even if favored energetically, this rearrangement has not been observed in solution. There, benzyl ion can stabilize itself by solvation or disappear through bimolecular processes. In the gas phase, however, where neither of these courses is available, one might expect the tropylium ion to be favored by the symmetrical structure, which permits the charge to be distributed equally throughout the ion.

### Reinterpretation of Anomalous Data

Viewing the dissociation of alkylbenzenes as proceeding through tropylium rather than benzyl ions leads to a reasonable explanation for anomalous data that have appeared recently in the literature. Peculiarities in correlations of spectra with structures, and inconsistencies in appearance potentials and derived thermochemical values have defined and focused attention on three questions: (a) why do the polymethylbenzenes so easily cleave at a ring-to-methyl bond when the same cleavage in toluene occurs but slightly? (b) Why do the spectra of disubstituted benzenes show no difference between *ortho-para* and *meta* isomers? (c) Why is the strength of the benzyl-hydrogen bond, as determined by the direct electron-impact method, significantly higher than the values obtained by the indirect electron-impact method and from pyrolysis studies?

**Loss of Methyl from Polymethylbenzenes.**—Correlations of structures with spectra of alkylbenzenes<sup>2,6</sup> indicate that the most abundant ion from dissociation by electron impact results nearly always from cleavage of a bond beta to the ring. But with the xylenes and other polymethylbenzenes, the most abundant ion forms by loss of a methyl group and nominally involves cleavage of a phenyl-methyl bond. Toluene itself shows only negligible cleavage of the phenyl-methyl bond. The difference may be explained by postulating that cleavage is preceded or accompanied by expansion to a seven-membered ring, and that the product is not tolyl but tropylium.

The same problem apparently is involved in some puzzling appearance potentials measured by Field and Franklin<sup>5</sup> for ions derived by the loss of a single methyl group

	Appear. poten., e.v.
$e + C_6H_5CH_3 \longrightarrow C_6H_5^+ + CH_3 + 2e$	13.80
$e + C_6H_4(CH_3)_2 \longrightarrow CH_3C_6H_4^+ + CH_3 + 2e$	<i>ortho</i> 11.73
	<i>meta</i> 11.78
	<i>para</i> 11.57
$e + C_6H_3(CH_3)_3 \longrightarrow (CH_3)_3C_6H_3^+ + CH_3 + 2e$	11.78

The energies of the tolyl ions calculated from these data are about 55 kcal. lower than that of the phenyl ion, but substitution of a second methyl group results in no further stabilization. On the

(16) J. L. Franklin and F. H. Field, *THIS JOURNAL*, **75**, 2819 (1953).

basis of group-orbital calculations, Field and Franklin predicted that a further lowering of more than a volt should be observed in going from tolyl to xylyl.<sup>5</sup>

The problem here is twofold. First, why does one methyl substituent stabilize the phenyl ion so much? Second, why does a second methyl substituent provide no additional stabilization? The electron-releasing effect of methyl cannot reasonably account for so much stabilization in tolyl ion. The hypothesis that the  $C_7H_7^+$  ion from xylene is tropylium and that the  $C_8H_9^+$  ion from trimethylbenzene is methyltropylium answers both questions. Introduction of the first methyl group allows rearrangement to the symmetrical, resonance-stabilized tropylium ion; introduction of the second methyl could lead only to methyltropylium, which should be little or no more stabilized than tropylium ion itself.

**Absence of Directive Effect in Isomeric Dialkylbenzenes.**—Correlation studies<sup>6</sup> have led to the generalization that product distribution from electron impact of dialkylbenzenes shows no evidence for the familiar distinction between *ortho-para* and *meta* isomers. Similarly, both the appearance potentials and the derived heats of formation of the isomeric methyl- and ethyl-substituted benzyl ions, formed by a common process, are identical within experimental error.<sup>5</sup> Again, if the dissociation process involves ring-expansion, the explanation follows directly. The benzene ring—in terms of which *ortho*, *meta* and *para* substitution are defined—has been destroyed, and the products from  $\beta$ -bond cleavage of the three isomers are identical

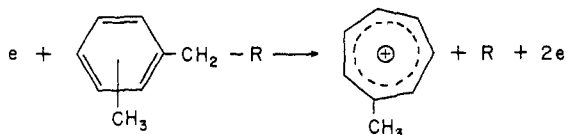

**Strength of the Benzyl-Hydrogen Bond.**—The strength of the benzyl-hydrogen bond has been the subject of many investigations. Pyrolysis studies on toluene have set the value at 77.5 kcal.<sup>15</sup> Electron-impact measurements<sup>4</sup> by the indirect method led to a value of  $77 \pm 3$  kcal., which agrees well with the thermal value. However, recent electron-impact measurements by the direct method gave 95 kcal.,<sup>9,17</sup> and the investigators were at a loss to explain the discrepancy between their value and the previous values. Again, the view that toluene under electron impact yields tropylium ion and not benzyl ion may provide an explanation for the discrepancy.

The direct electron-impact method<sup>18</sup> of determining the dissociation energy of the benzyl-hydrogen bond requires measuring both the appearance potential of the benzyl ion,  $A(C_7H_7^+)$ , and the ionization potential of the benzyl radical,  $I(C_7H_7\cdot)$ .<sup>9</sup> The dissociation energy,  $D(C_7H_7-H)$ , is then

$$D(C_7H_7-H) = A(C_7H_7^+) - I(C_7H_7\cdot)$$

(17) J. B. Farmer, F. P. Lossing, D. G. H. Marsden and C. A. McDowell, *J. Chem. Phys.*, **24**, 52 (1956).

(18) D. P. Stevenson, *Disc. Faraday Soc.*, **10**, 35 (1951).

If 77 kcal. is accepted as the bond-dissociation energy, then the measured appearance potential for the "benzyl" ion, 11.8 e.v., is too high by 0.7 e.v.; formation of benzyl ion should require only 11.1 e.v. More likely, 11.8 e.v. is the appearance potential of the tropylium ion.

Figure 1 illustrates how it is possible for the higher-energy process to be the preferred one. The rearrangement is pictured as requiring less

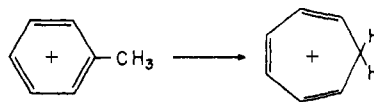

activation energy and therefore as faster than the dissociation

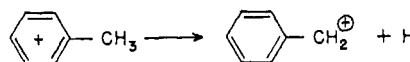

Once formed, cycloheptatriene molecule-ion cannot yield benzyl ion; the only path open leads to tropylium ion plus hydrogen. If, as seems likely, the heat of formation of the tropylium ion is less than that of the benzyl ion, the data demand that the reverse reaction have an activation energy of

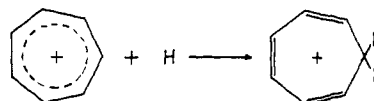

at least 0.7 e.v. This value is quite reasonable because conversion of one ion to the other requires considerable change in carbon-carbon bonding distances. In the tropylium ion, all adjacent carbons are equidistant; in the cycloheptatriene molecule-ion, they alternate between single- and double-bond distances.

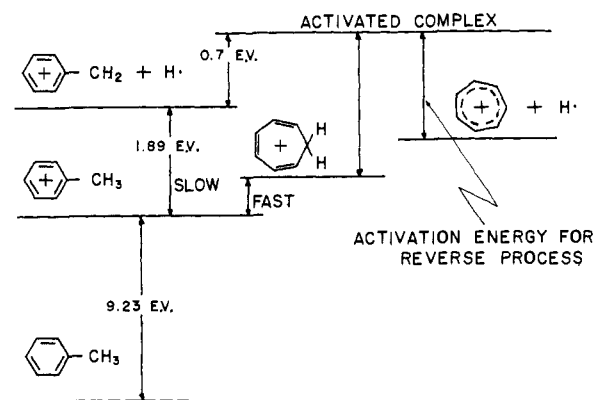

Fig. 1.—Energy levels.

Schissler and Stevenson,<sup>4</sup> using the indirect method of determining bond energies by electron impact, arrived at 77 kcal. for the benzyl-hydrogen bond strength, even though they used appearance potentials that were too high by 0.7 e.v., or 16.1 kcal. Their agreement with the thermal value may be fortuitous and arises from the nature of the calculation. In this method the appearance potentials of the same ion produced from two different but related molecules are measured, and the

difference is combined with thermochemical data to give the required dissociation energy. If both measured appearance potentials contain the same excess energy term, it drops out when the difference is taken.

### Experimental

Ethylbenzene- $\alpha$ - $d$  and - $\beta$ - $d$  were prepared by reducing  $\alpha$ -chloro- and  $\beta$ -chloroethylbenzene with  $\text{LiAlD}_4$ .<sup>19</sup> Ethylbenzene- $\alpha$ - $d_2$  was made by the disproportionation of ethylbenzene- $\alpha$ - $d$  in the presence of potassium.<sup>19</sup> Ethylbenzene- $o$ - $d$ , - $m$ - $d$  and - $p$ - $d$  were made from the appropriate bromo-magnesium-ethylbenzenes by addition of  $\text{D}_2\text{O}$  of 99.8%<sup>o</sup>

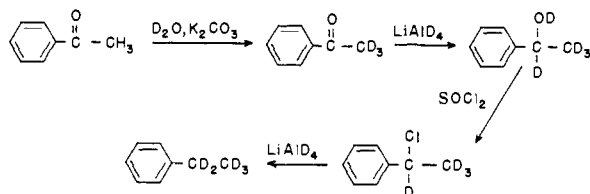

(19) H. Hart, *THIS JOURNAL*, **78**, 2619 (1956).

isotopic purity. Ethylbenzene- $\alpha,\beta$ - $d_5$  was prepared by the formula sequence shown.

The spectra were recorded on a Consolidated model 21-102 mass spectrometer. Isotopic species were determined from spectra obtained at an ionizing voltage sufficient to ionize molecules but insufficient to remove hydrogen atoms from the molecule-ions.<sup>20,21</sup> Spectra of the monodeuteroethylbenzenes and toluenes were corrected for contributions from undesired isotopic species.

**Acknowledgment.**—The ring-deuterated ethylbenzenes and ethylbenzene- $\alpha,\beta$ - $d_5$  were prepared by C. J. Norton. The ethylbenzene- $\alpha$ - $d$ , - $\beta$ - $d$  and  $\alpha$ - $d_2$  were prepared by Harold Hart of Michigan State College. Toluene- $\alpha$ - $d_3$  and - $p$ - $d$  were kindly supplied by H. C. Brown of Purdue University. Toluene- $\alpha$ - $d$ , - $o$ - $d$  and - $m$ - $d$  were kindly supplied by E. L. Eliel of the University of Notre Dame.

(20) R. E. Honig, *Anal. Chem.*, **22**, 1474 (1950).

(21) D. P. Stevenson and C. D. Wagner, *THIS JOURNAL*, **72**, 5612 (1950).

WHITING, INDIANA

[CONTRIBUTION FROM THE DEPARTMENT OF CHEMISTRY AND THE RESEARCH LABORATORY OF ELECTRONICS, MASSACHUSETTS INSTITUTE OF TECHNOLOGY]

## Nuclear Resonance Spectra of Hydrocarbons: The Free Electron Model

By J. S. WAUGH AND R. W. FESSENDEN

RECEIVED SEPTEMBER 4, 1956

The classical free electron model of Pople is used to predict the high resolution nuclear resonance spectra of some hydrocarbons. The modifications necessary to describe the spectra of simple substituted benzenes are discussed. Some previous measurements by other workers of the spectra of condensed aromatic substances are repeated somewhat more precisely, and agree only very crudely with the simple free electron theory. The spectra of two 1,4-polymethylenebenzenes are predicted and support the fundamental ideas of Pople. The spectrum of 2,2-paracyclophane is also reported.

Pople<sup>1</sup> has proposed recently a classical free electron model to account for the chemical shifts in nuclear resonance spectra of protons attached to aromatic rings. As in Pauling's<sup>2</sup> theory of the diamagnetic anisotropy of aromatic substances, the  $\pi$  electrons are considered to acquire a circulation about the ring as it is immersed in a magnetic field. The resulting supercurrent is responsible for a diamagnetic moment whose field is felt by nearby nuclei. Pople<sup>3</sup> has applied this model to an interpretation of the spectra of condensed hydrocarbons reported by Bernstein and Schneider.<sup>4</sup> Qualitative agreement was obtained despite the facts that: (1) the diamagnetic ring current, taken in the plane of the molecule, was replaced by an equivalent point dipole and (2) the available experimental data provided only *relative* chemical shifts, uncorrected for the effects of bulk diamagnetism.

In this paper we comment on the effects of refining the calculations somewhat (still preserving their classical basis) upon the quality of the agreement with an improved version of some of Bernstein and Schneider's results, and we also report on a test of the free electron hypothesis using molecules not all of whose protons are confined to the plane of an aromatic ring.

(1) J. A. Pople, *J. Chem. Phys.*, **24**, 1111 (1956).

(2) L. Pauling, *ibid.*, **4**, 673 (1936).

(3) J. A. Pople, private communication.

(4) H. J. Bernstein and W. G. Schneider, *J. Chem. Phys.*, **24**, 468 (1956).

### Experimental

The sources of our samples and information bearing on their purities are shown in Table I.

Spectra were obtained with a Varian Associates V-4300-B high resolution spectrometer at a frequency of 40 Mc. Chemical shifts were measured with reference to a sealed Pyrex capillary filled with water and placed inside the 5 mm. Pyrex tube containing the sample. Where convenient, measurements were made by the method of superposing audio-frequency sidebands from a calibrated Hewlett Packard 200-I oscillator,<sup>5</sup> giving a precision for sharp lines of about  $\pm 1$  c.p.s. In other cases the shifts were read from recordings of the spectrum, corrected for sweep non-linearity. For substances very soluble in  $\text{CCl}_4$ , the shifts were determined at volume fractions of solute of approximately 1, 0.25, 0.06 and 0.015, and extrapolated to zero. In other cases, e.g., 2,2-paracyclophane, a single measurement was made at a very low concentration.

#### Calculations: The Chemical Shift in Benzene.—

As Pople<sup>1</sup> points out, a superconducting circular loop in a field  $\mathbf{H}_0$  carries a current  $I = e^2 \mathbf{H}_0 \cdot \mathbf{n} / 4 \pi m c$  for each free electron, where  $\mathbf{n}$  is a unit vector normal to the plane of the loop. In cylindrical coordinates  $(\rho, \phi, z)$ , referred to the loop and measured in units of its radius  $a$ , the  $z$ -component of this field is

$$H_z' = \frac{Ik}{4\pi ca\rho^{1/2}} \left[ K(k) + \frac{1 - \rho^2 - z^2}{(1 - \rho)^2 + z^2} E(k) \right]$$

$$k^2 = \frac{4\rho}{(1 + \rho)^2 + z^2}$$

(5) J. T. Arnold and M. E. Packard, *ibid.*, **19**, 1608 (1951).